

Akord Furniture Factory

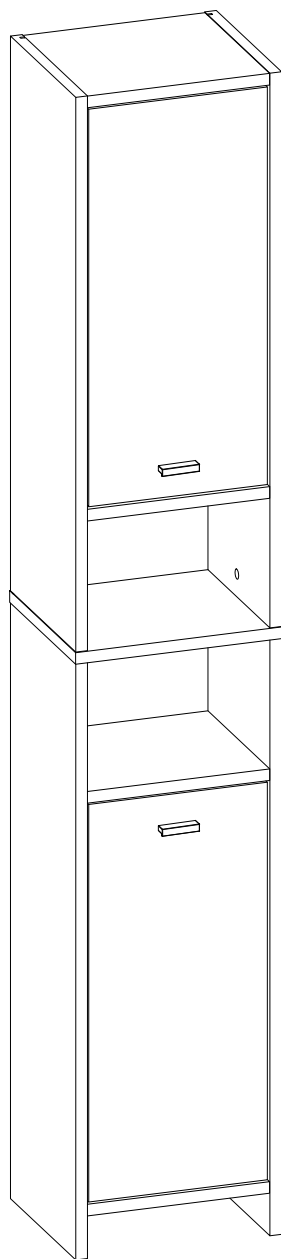

REGAŁ ŁAZIENKOWY BETI 2D

- PL** **REGAŁ ŁAZIENKOWY BETI 2D**
Instrukcja montażu
- HU** **FÜRDŐ KABIN BETI 2D**
Összeszerelési útmutató
- BG** **ШКАФ В БАНЯТА BETI 2D**
Инструкция за монтаж
- DE** **BADEZIMMERSCHRANK BETI 2D**
Montageanleitung
- CZ** **KÚPELŇOVÁ SKRINKA BETI 2D**
Návod k montáži
- SK** **KÚPELŇOVÁ SKRINKA BETI 2D**
Návod na montáž
- RO** **Dulap pentru baie BETI 2D**
Instrucțiuni de instalare
- LT** **VANNAS SKAPIS BETI 2D**
Montavimo instrukcija

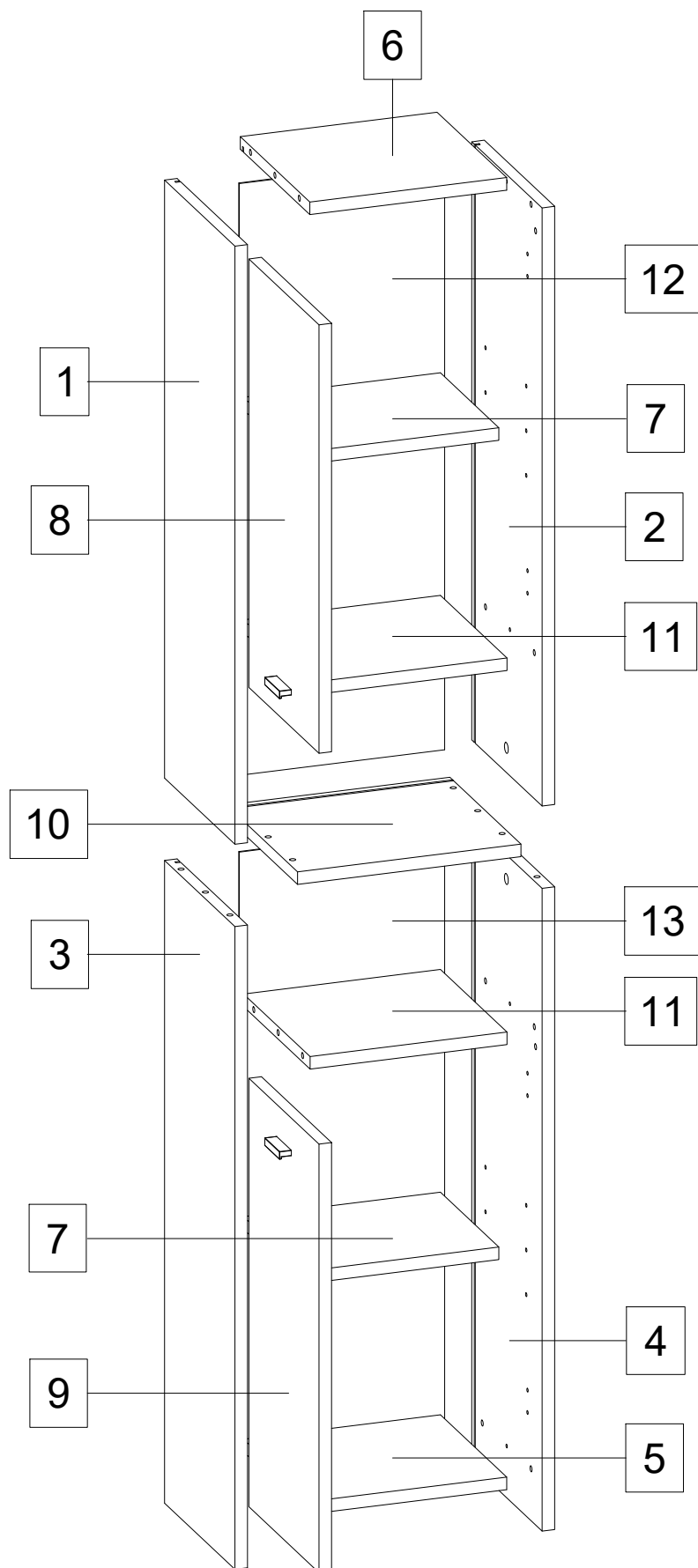

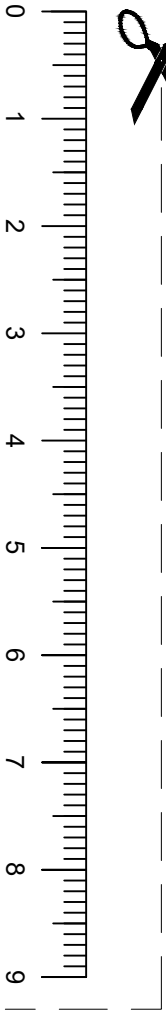

Potrzebne są:
Szükségesek:
Са нужни:
Wird gebraucht:
Jsou potřeba:
Sú potrebné:
Sunt necesare:
Ir nepieciešami:

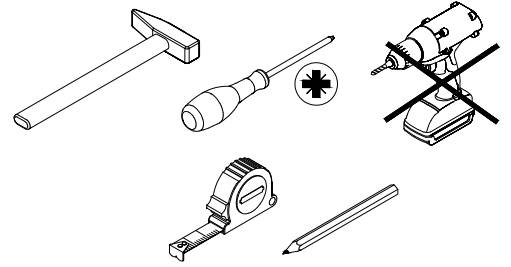
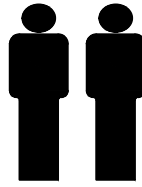

16x 14

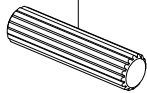

4x 15

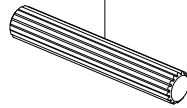

8x 16

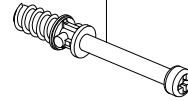

2x 17

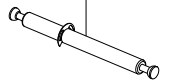

12x 18



4x 19



6x 20



1x 21

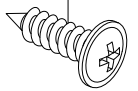

1x 22

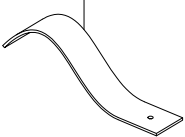

2x 23

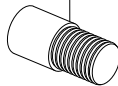

8x 24

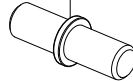

4x 25

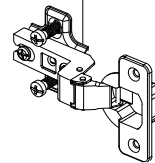

8x 26

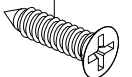

2x 27

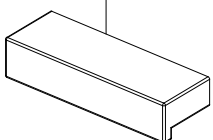

4x 28

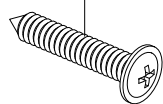

4x 29

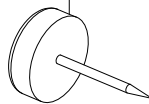

12x 30

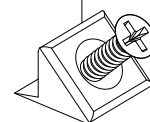

1x 31

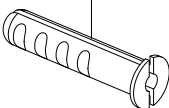

1x 32

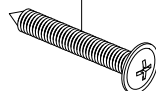

Części:
Alkatrészek:
части:
Teile:
Části:
Părți:
Daļas:

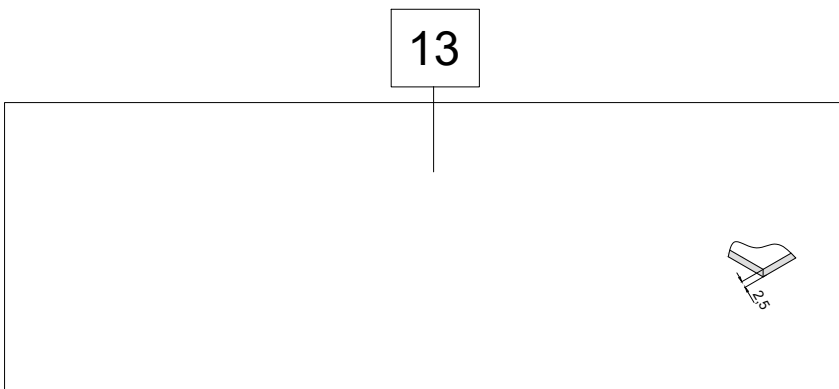
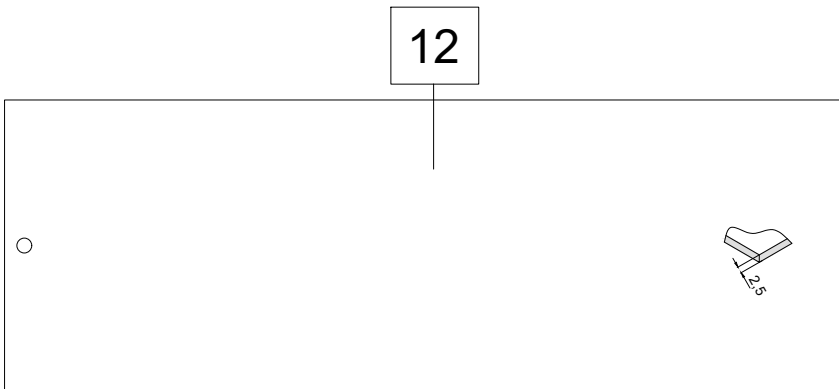
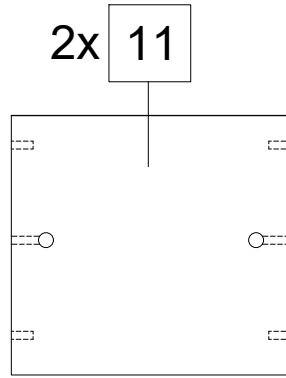
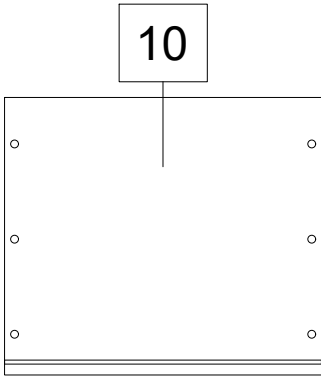
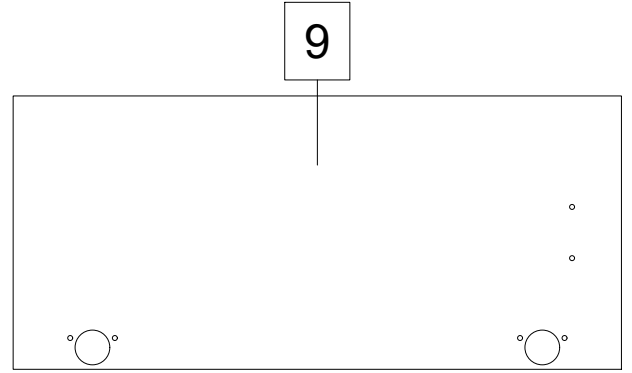
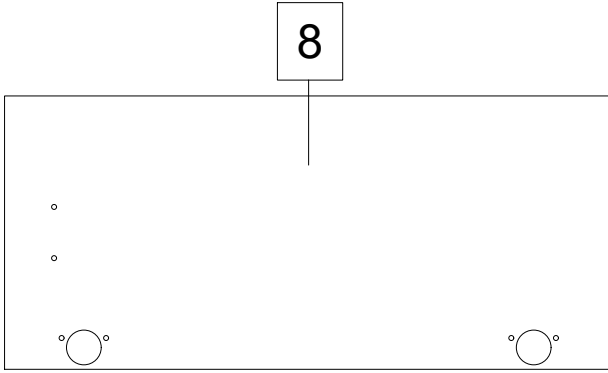
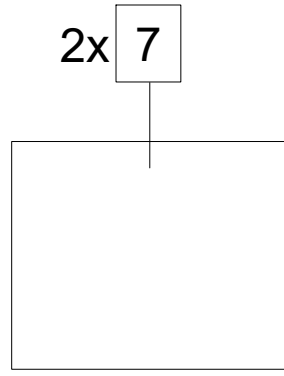
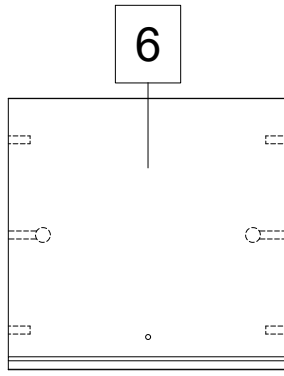
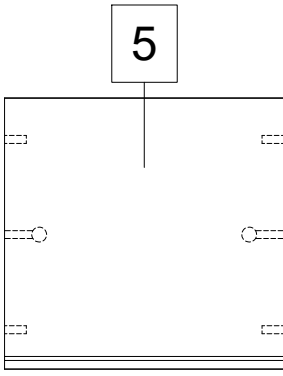

- PL** Uwaga o zagrożeniach :
Uwaga: Montaż należy przeprowadzić dokładnie według wytycznych producenta, w innym przypadku może to prowadzić do naruszenia bezpieczeństwa. Przy wadliwym montażu istnieje zagrożenie dla bezpieczeństwa.
Wykonanie prac montażowych należy zlecić specjalście!
Uwaga o pielęgnacji: Czyścić tylko przy pomocy suchej lub wilgotnej ściereczki. Nie stosować środków do szorowania!
Określony zakres zastosowania: Produkt przeznaczony do użytku w mieszkaniu.
- HU** **Veszélyekre vonatkozó felhívás:**
Figyelem: A szerelést pontosan a gyártó iránymutatásainak megfelelően kell elvégezni, ellenkező esetben az a biztonság megsértéséhez vezethet. A nem megfelelő összeszerelés balesetveszéllyel járhat. Az összeszerelési tevékenységeket szakember végezze!
Karbantartásra vonatkozó felhívás: Csak száraz vagy nedves ronggyal tisztítsa. Ne használjon súrolószereket!
Meghatározott alkalmazási kör: A termék beltérben használandó.
- BG** **Забележка относно опасностите:**
Внимание: Монтажът трябва да се извърши точно съгласно указанията на производителя, в противен случай това може да доведе до нарушение на безопасността. При неправилен монтаж съществува риск за безопасността. Монтажните дейности трябва да се възложат на специалист!
Забележка относно поддръжката: Да се почиства само със суха или влажна кърпа. Да не се използват абразивни препарати!
Определен обхват на използване: Продуктът е предназначен за използване в жилищна среда.
- DE** **Sicherheitshinweis:**
Achtung: Die Montage muss exakt nach den Anweisungen des Herstellers erfolgen - anderenfalls kann eine fehlerhafte Montage zu einem Sicherheitsrisiko führen. Bei mangelhafter Montage besteht Gefahr für die Sicherheit. Aufbau durch fachkundiges Personal empfohlen!
Pflegehinweis:
Bitte nur mit einem Staubtuch oder einem feuchten Lappen reinigen. Keine scheuernden Putzmittel verwenden!
Bestimmungsgemäße Verwendung:
Produkt nutzbar für den privaten Wohnbereich.
- CZ** **Bezpečnostní pokyn:**
Upozornění: Montáž provádějte přesně podle pokynů výrobce, jinak by to mohlo vést k narušení bezpečnosti. Při nesprávné montáži vzniká nebezpečí úrazu. Provedení montážních prací svěťte odborníkovi!
Poznámka k ošetřování: Čistěte pouze suchým nebo vlhkým hadříkem. Nepoužívejte abrazivní prostředky!
Určená doba použití: Výrobek je určen pro používání v bytě.
- SK** **Poznámka o rizikách:**
Pozor: Inštalácia by mala byť vykonaná presne v súlade s pokynmi výrobcu, inak by mohlo dôjsť k narušeniu bezpečnosti. Pri chybných inštaláciách hrozí riziko nebezpečenstva. Vykonávanie montážnych prác je nevyhnutné ponechať na odborníkov!
Poznámka k správne mu užívaniu: Čistite len suchou alebo vlhkou handričkou. Nepoužívajte drsné čistiace prostriedky!
Definovaný rozsah využitia: Výrobok je určený na používanie v byte.
- RO** **Notă cu privire la riscurile:**
Notă : Montajul se va efectua exact după indicațiile producătorului, în caz contrar securitatea poate fi încălcată. la instalarea defectuoasă, există un risc de securitate. Executarea lucrărilor de montaj trebuie fi comandată la specialist!
Notă privind îngrijirea: Curățați numai cu o cârpă uscată sau umedă. Nu folosiți agenți de curățat! **Definit domeniul de aplicare:** Produsul este destinat utilizării în apartament.
- LT** **Įspėjimas apie pavojus:**
Dėmesio: Montavimas turi būti atliekamas tiksliai pagal gamintojo nurodymus, priešingu atveju kyla pavojus saugumui. Prie neatitinkamo sumontavimo kyla grėsmė saugumui. Montavimo darbus turi atlikti specialistas!
Įspėjimas dėl priežiūros: Valyti tik su sausu arba drėgnu skudurėliu. Nenaudoti abrazyvinių priemonių!
Apibrėžta panaudojimo sritis: Produktas skirtas naudoti gyvenamuosiuose butuose.

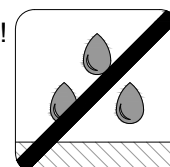

A1

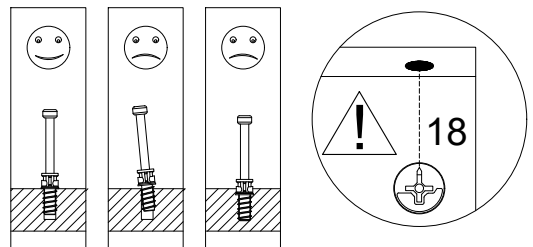
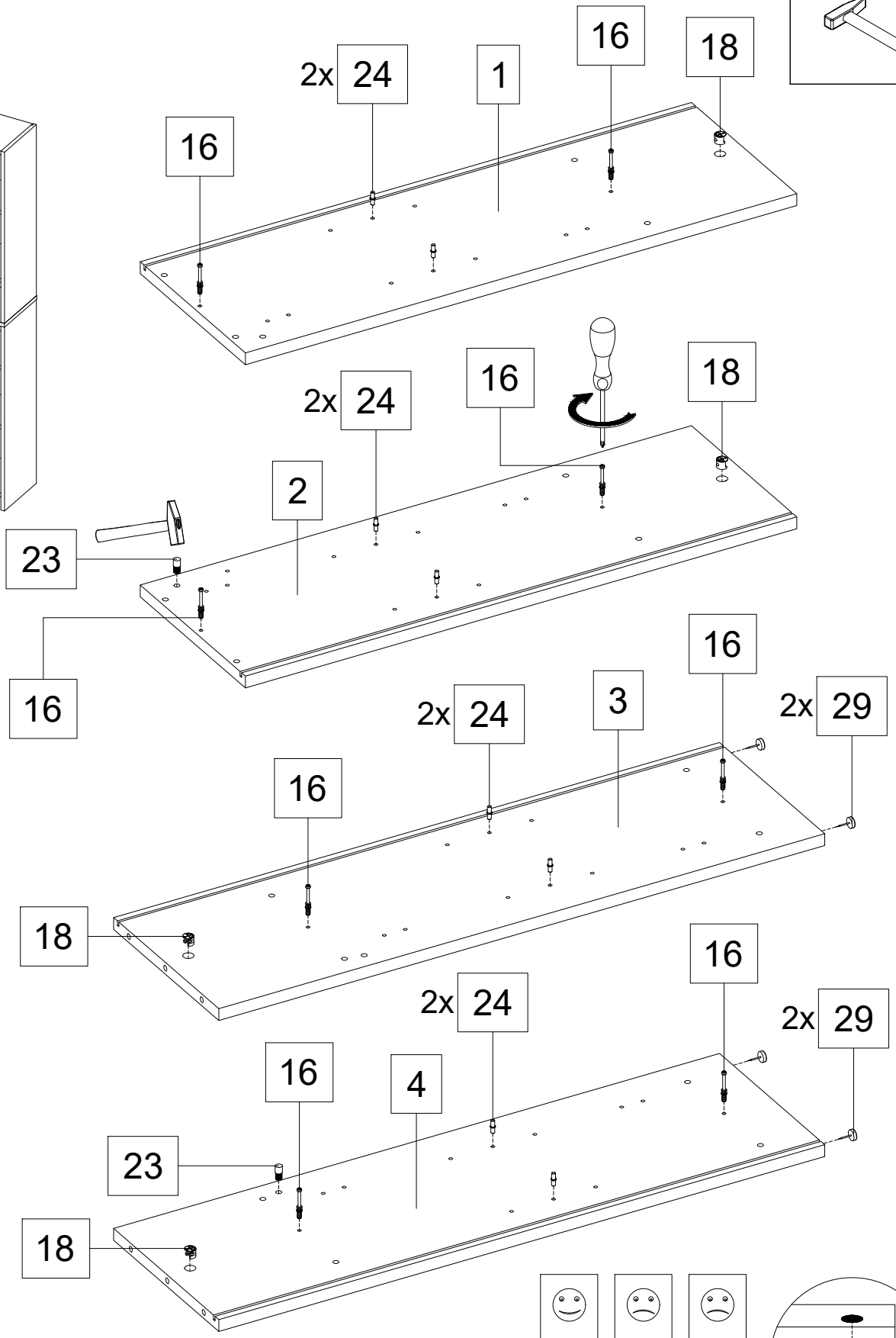
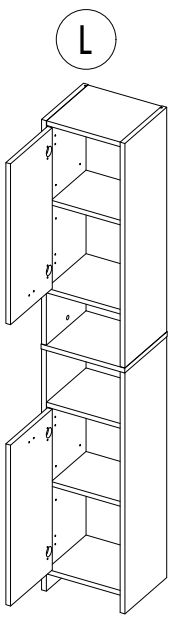
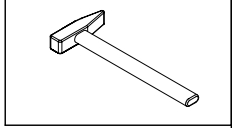
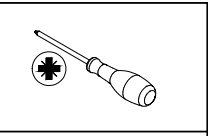
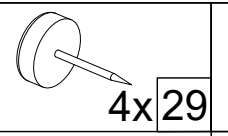
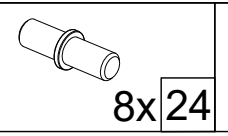
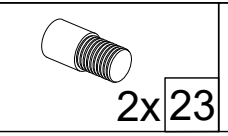
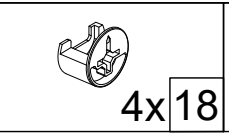
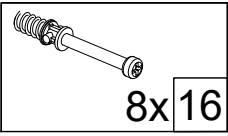

A2

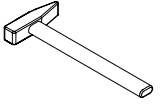
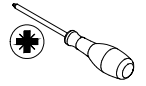
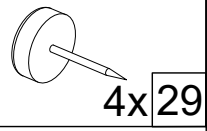
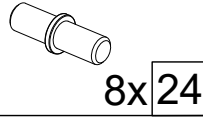
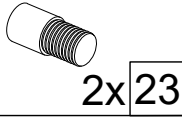
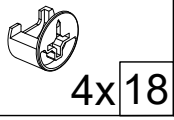
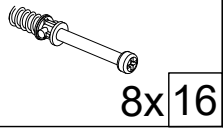

R

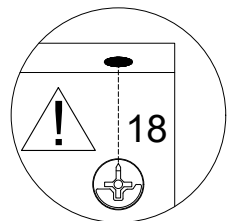
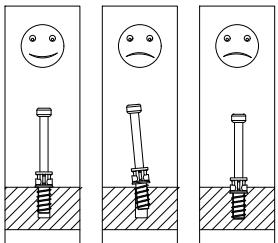
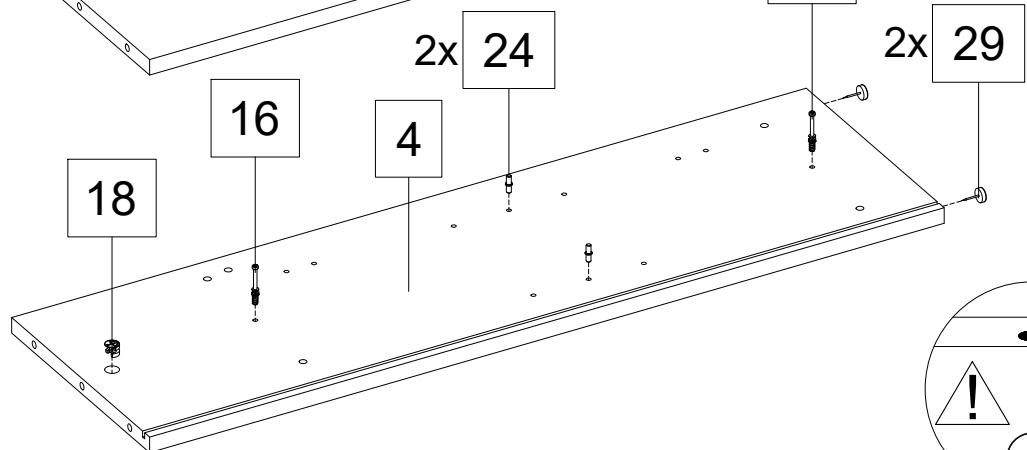
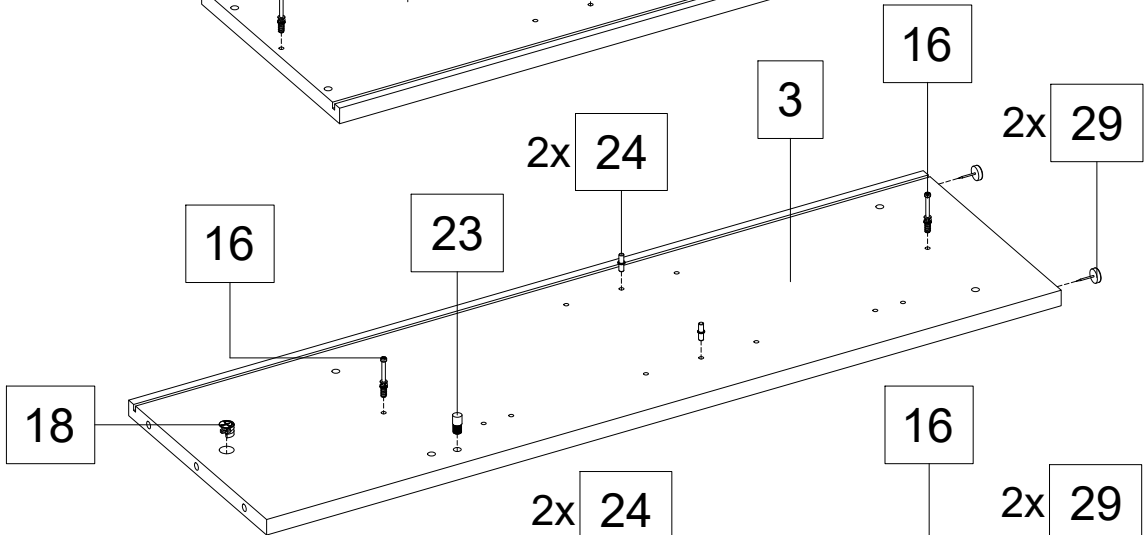
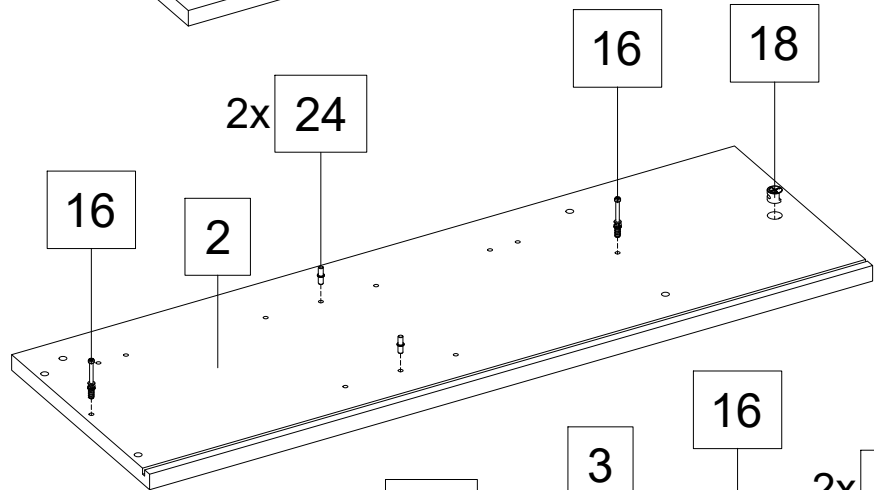
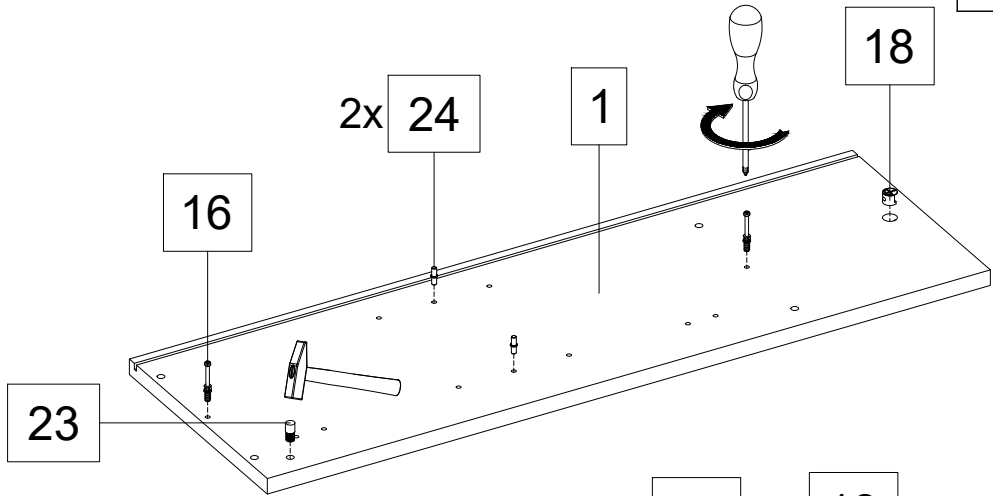
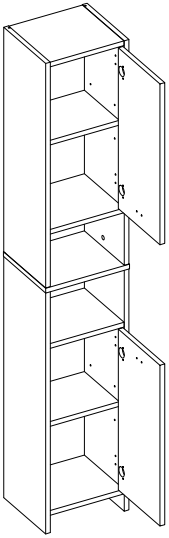

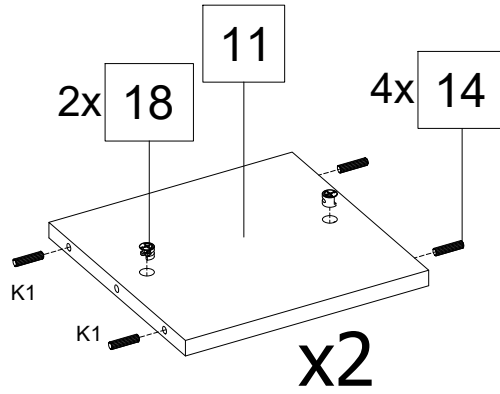
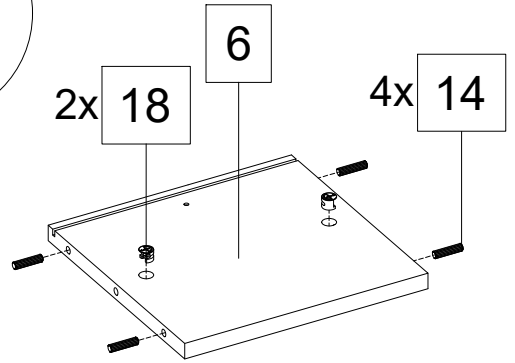
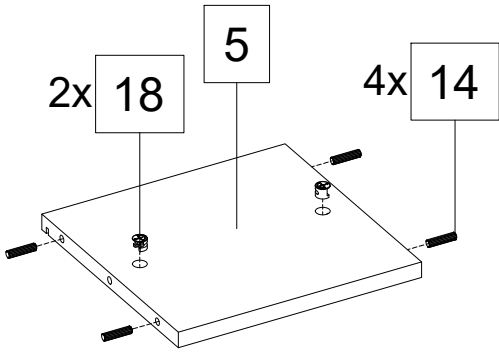
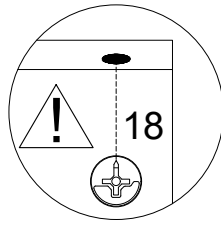
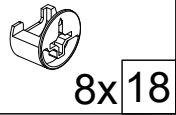
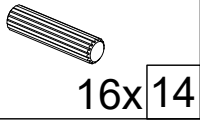
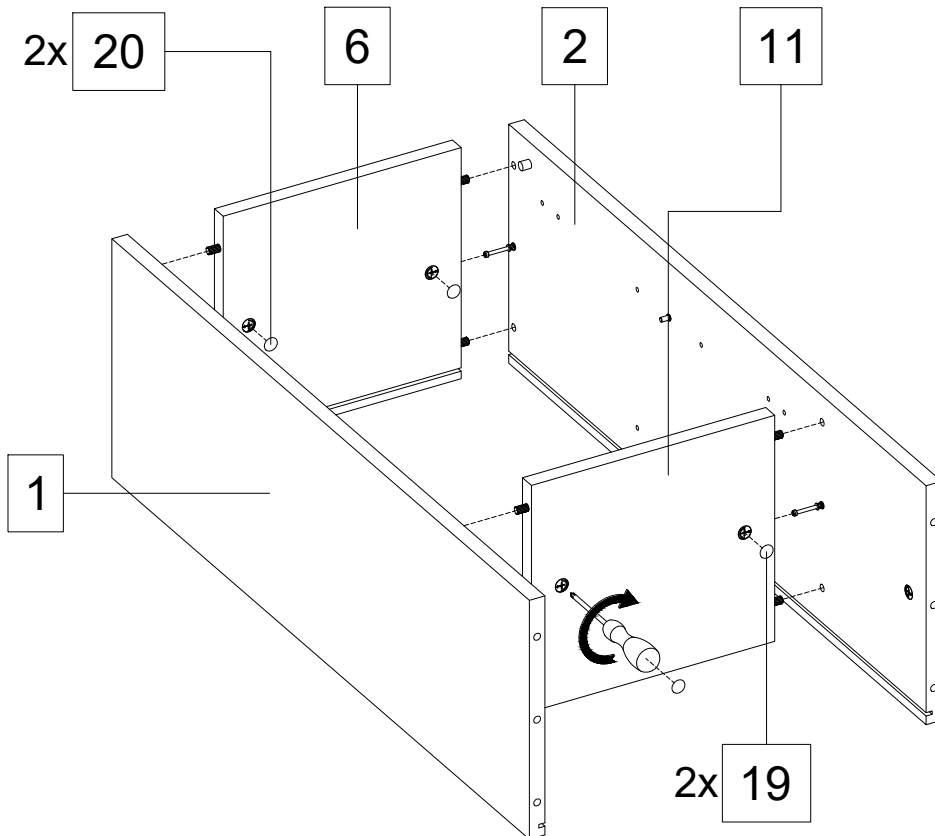
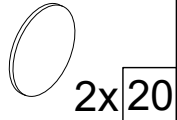
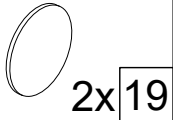
B**C**

D

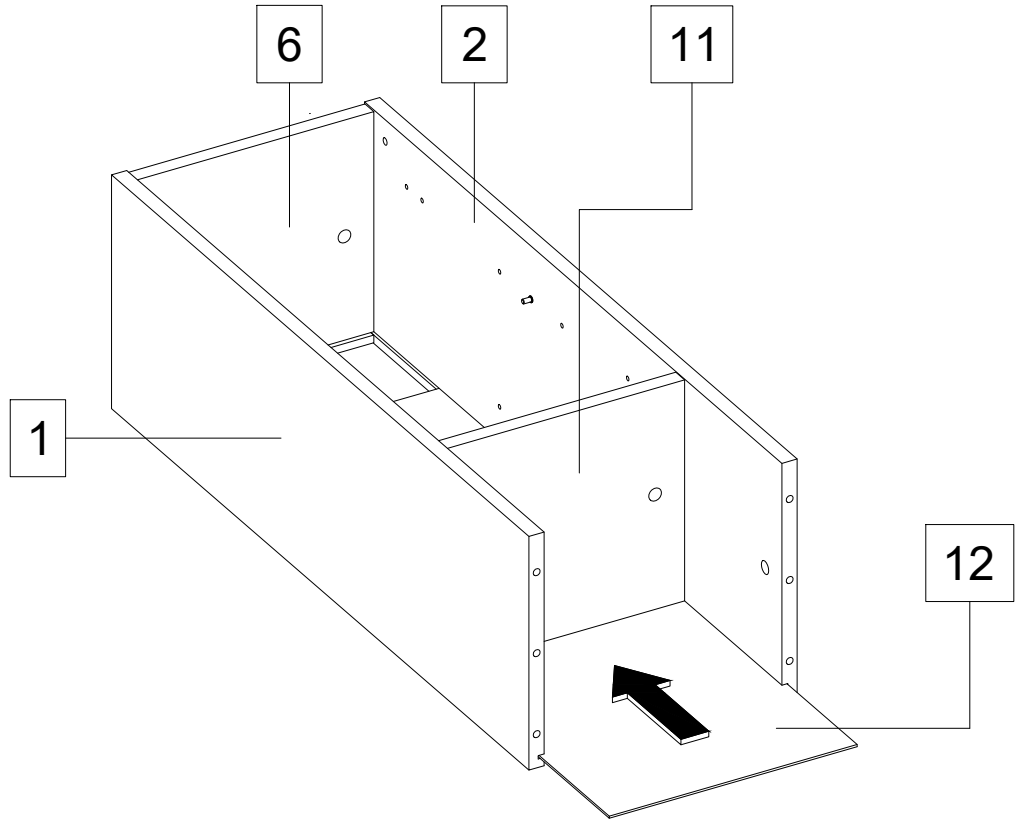

E

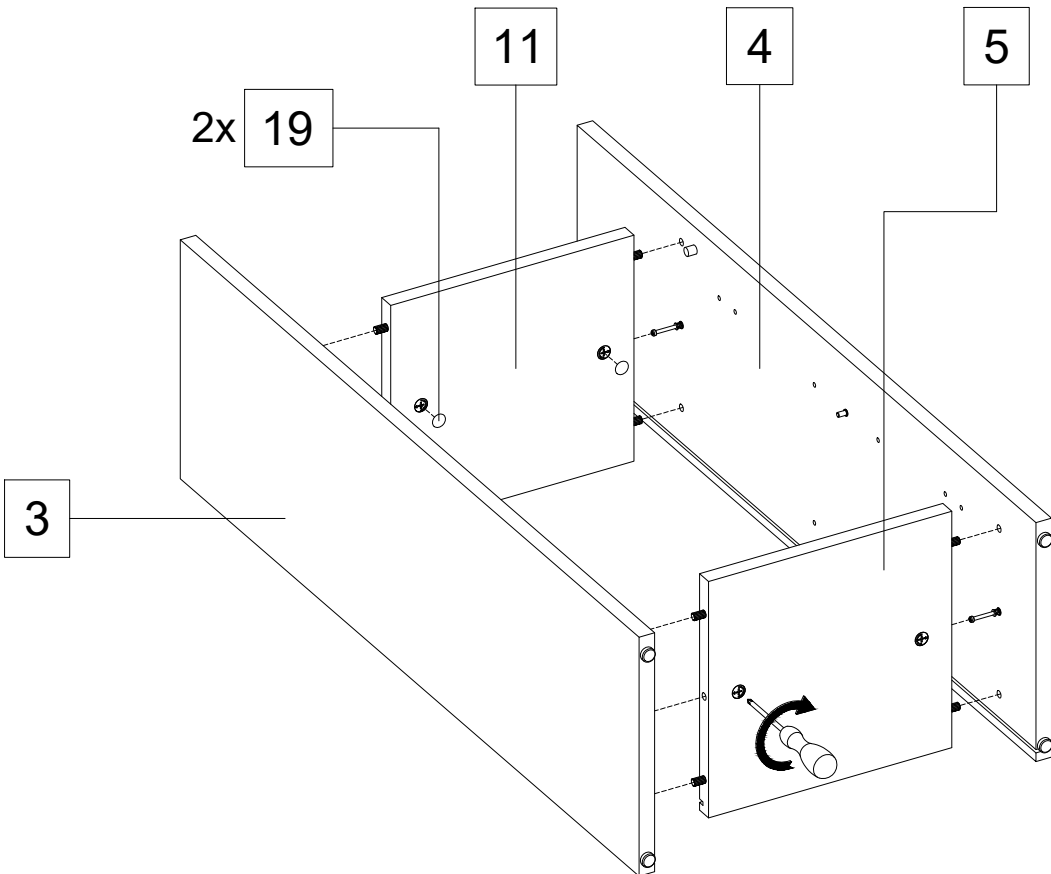
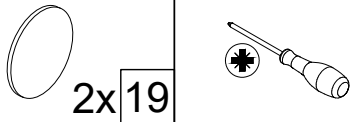

F

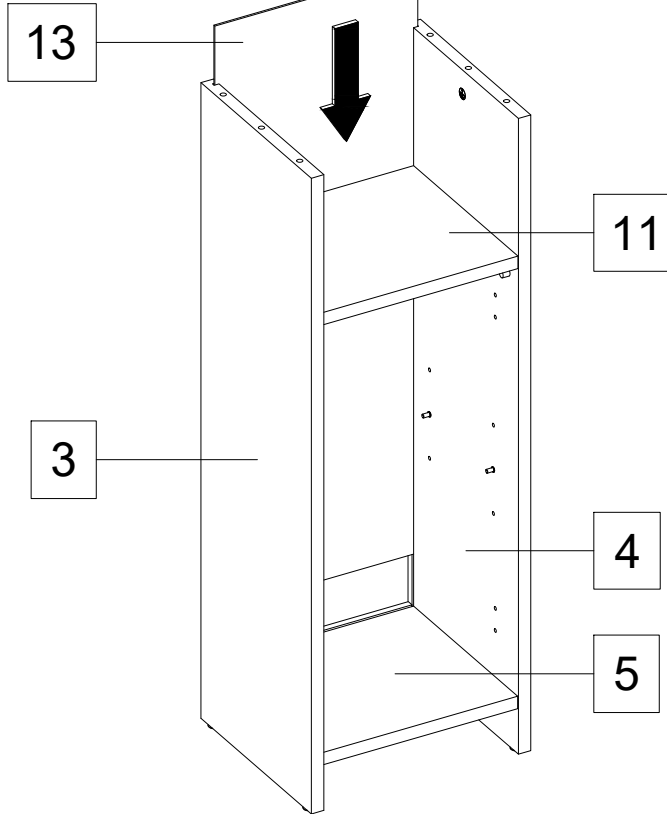

G



4x 15

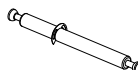

2x 17



2x 20

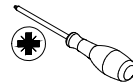

10

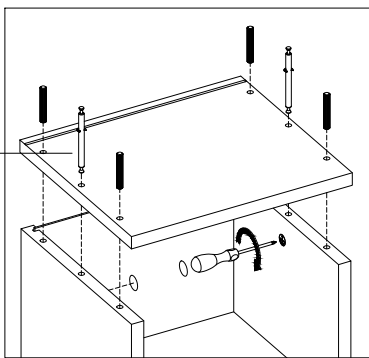

11

3

4

5

4x 15

10

2x 17

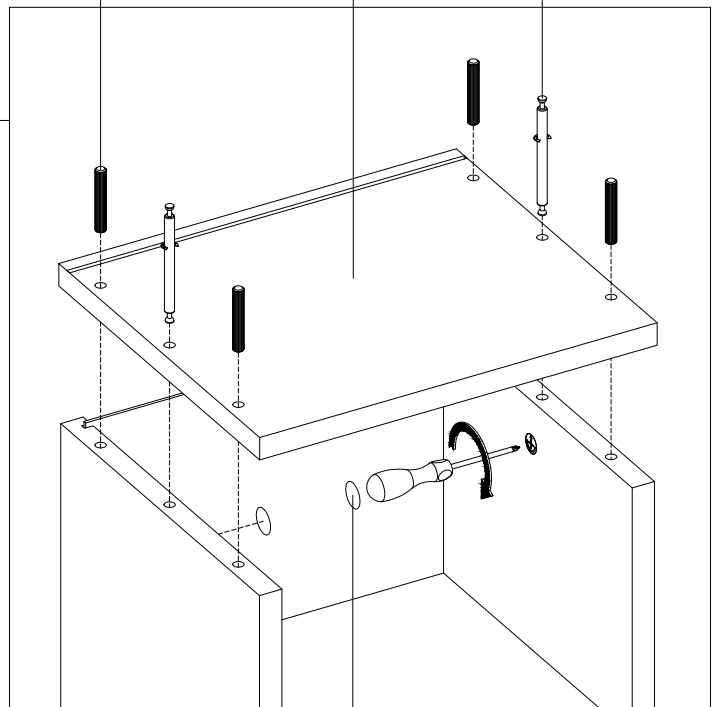

2x 20

H

2x 20

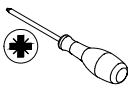

6

1

10

3

5

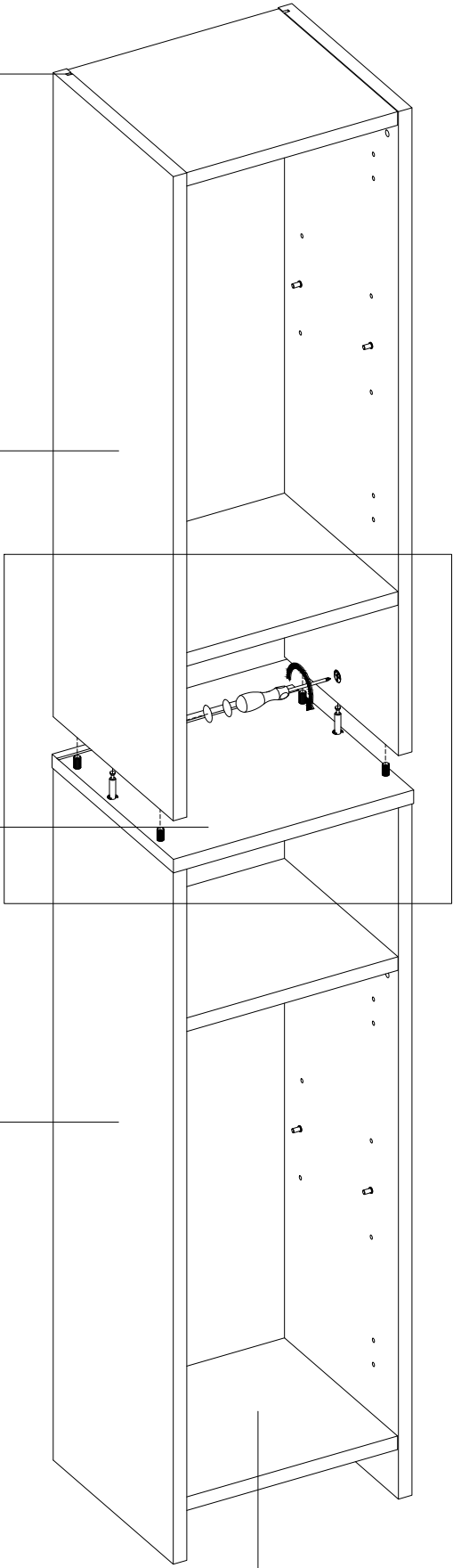

2x 20

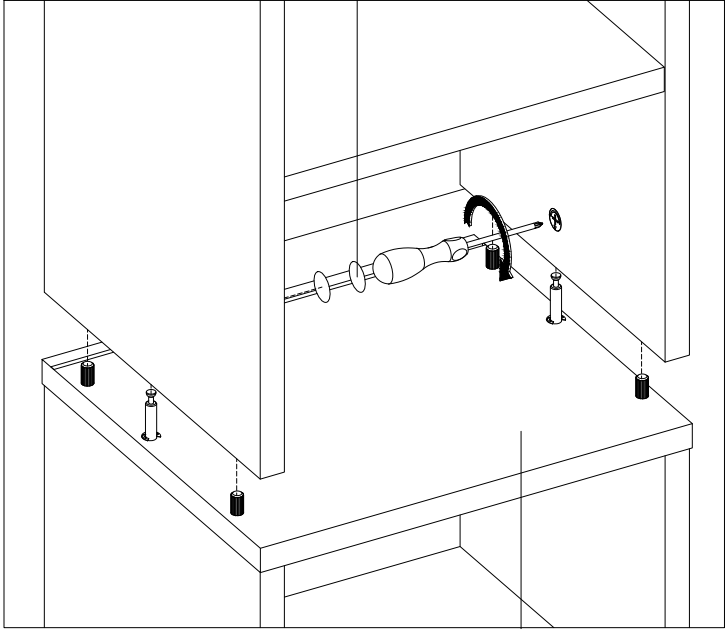

10

I

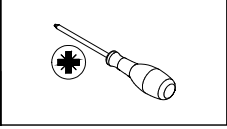
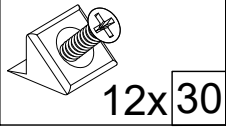

$XX=YY \cong 90^\circ$

12

12x 30

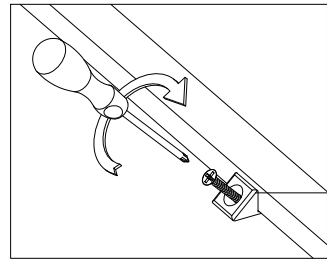

30

2

13

4

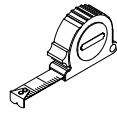
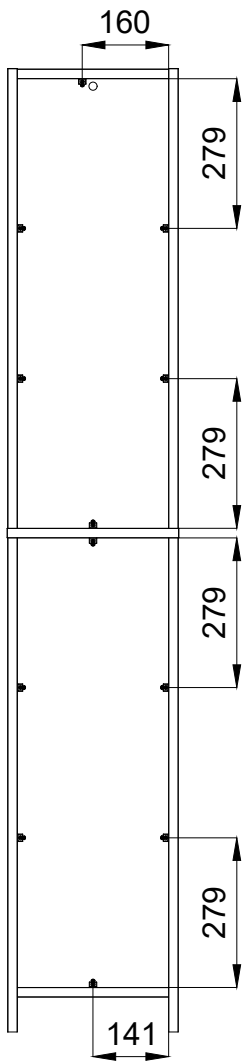

J

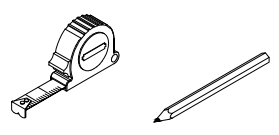
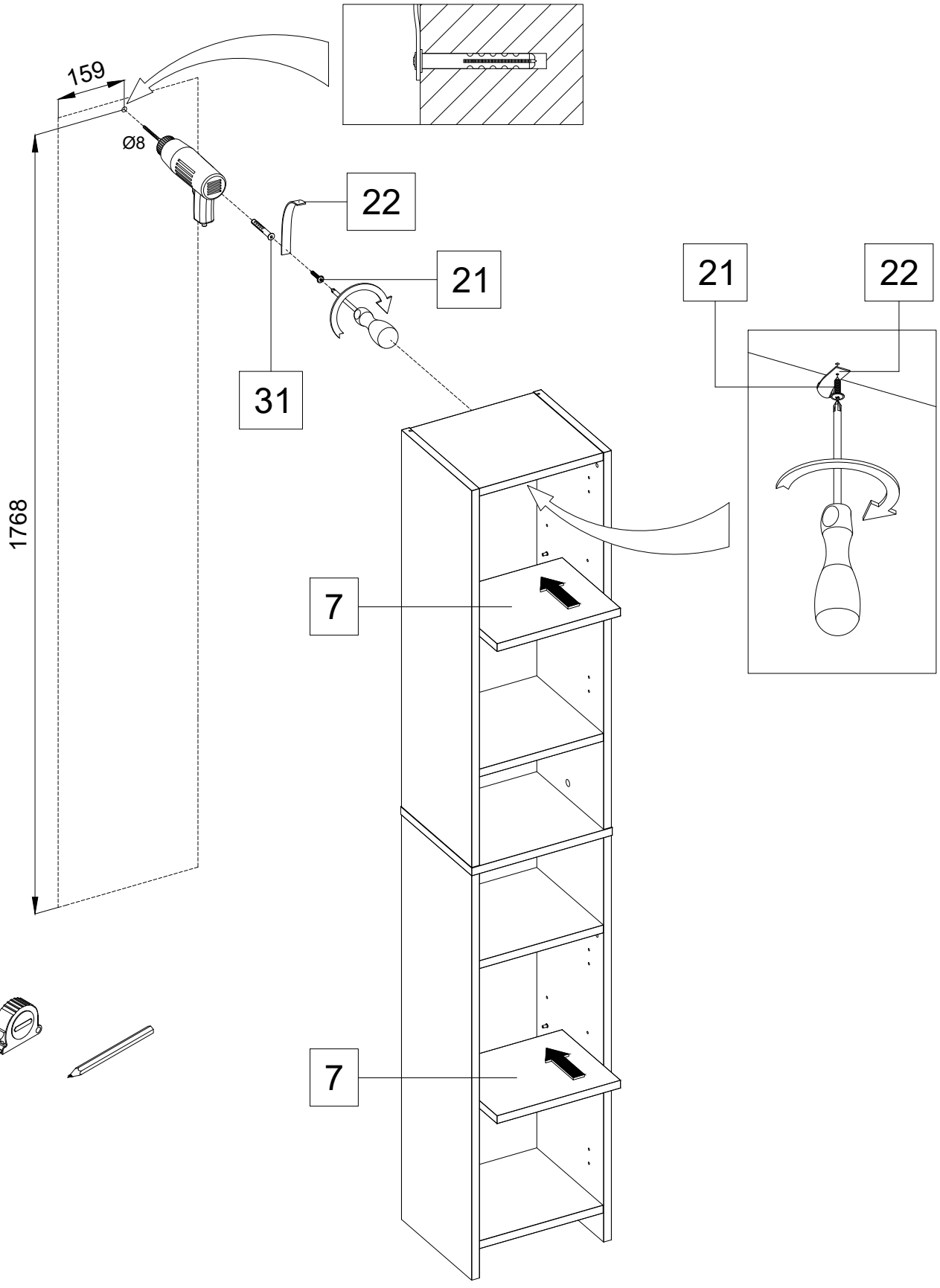
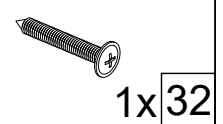
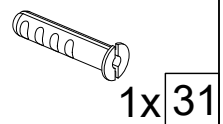
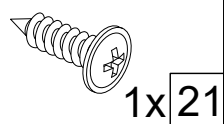
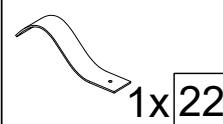

-
- PL** **Sposób montażu do ściany:**
UWAGA: W celu uniknięcia przewrócenia, należy zastosować wskazane mocowanie do ściany. W przypadku użycia środków złącznych do mocowania do ściany należy sprawdzić zdatność materiału nośnego.
- HU** **Falhoz rögzítés módja:**
HU FIGYELEM: A felborulás megelőzése érdekében a falhoz kell erősíteni a bemutatott módon. Amennyiben rögzítő eszközöket használ a falra szerelés során, úgy le kell ellenőrizni a hordozóanyag alkalmasságát.
- BG** **Начин на монтаж към стената:**
ВНИМАНИЕ: С цел избягване на преобръщането е необходимо да се приложи посоченият прикрепващ елемент към стената. В случай на използване на съединителни елементи за монтаж към стената, трябва да проверите, дали носещият материал е подходящ.
- DE** **Wandmontage:**
WARNHINWEIS: Um ein Umkippen zu verhindern, ist dieses Produkt mit dem mitgelieferten Schrankaufhänger zu verwenden. Bei Verbindungsmittel für die Wandbefestigung ist das Trägermaterial auf Eignung zu prüfen.
- CZ** **Způsob montáže na stěnu:**
UPOZORNĚNÍ: Aby se zabránilo převrácení, použijte uvedené připevnění ke zdi. Pokud budete používat spojovací prvky pro připevnění na stěnu, zkontrolujte únosnost podkladu.
- SK** **Spôsob montáže na stenu:**
UPOZORNENIE: Aby sa predišlo pádu, je nevyhnutné použiť určené upevnenie do steny. V prípade použitia spojovacích materiálov na upevnenie na stenu je potrebné skontrolovať vhodnosť nosného materiálu.
- RO** **Montarea pe perete:**
ATENȚIE: Pentru a evita răsturnare, se va aplica fixarea la perete indicată. În cazul utilizării de mijloace de cuplare pentru atașarea la perete trebuie verificat caracterul adecvat al materialului purtător.
- LT** **Būdas primontuoti prie sienos:**
DĖMESIO: Naudoti nurodytą tvirtinimą prie sienos, kad baldas neapvirstų. Jei montavimui prie sienos bus naudojami dalys esančios rinkinyje, reikia patikrinti laikančiosios medžiagos tinkamumą.

K

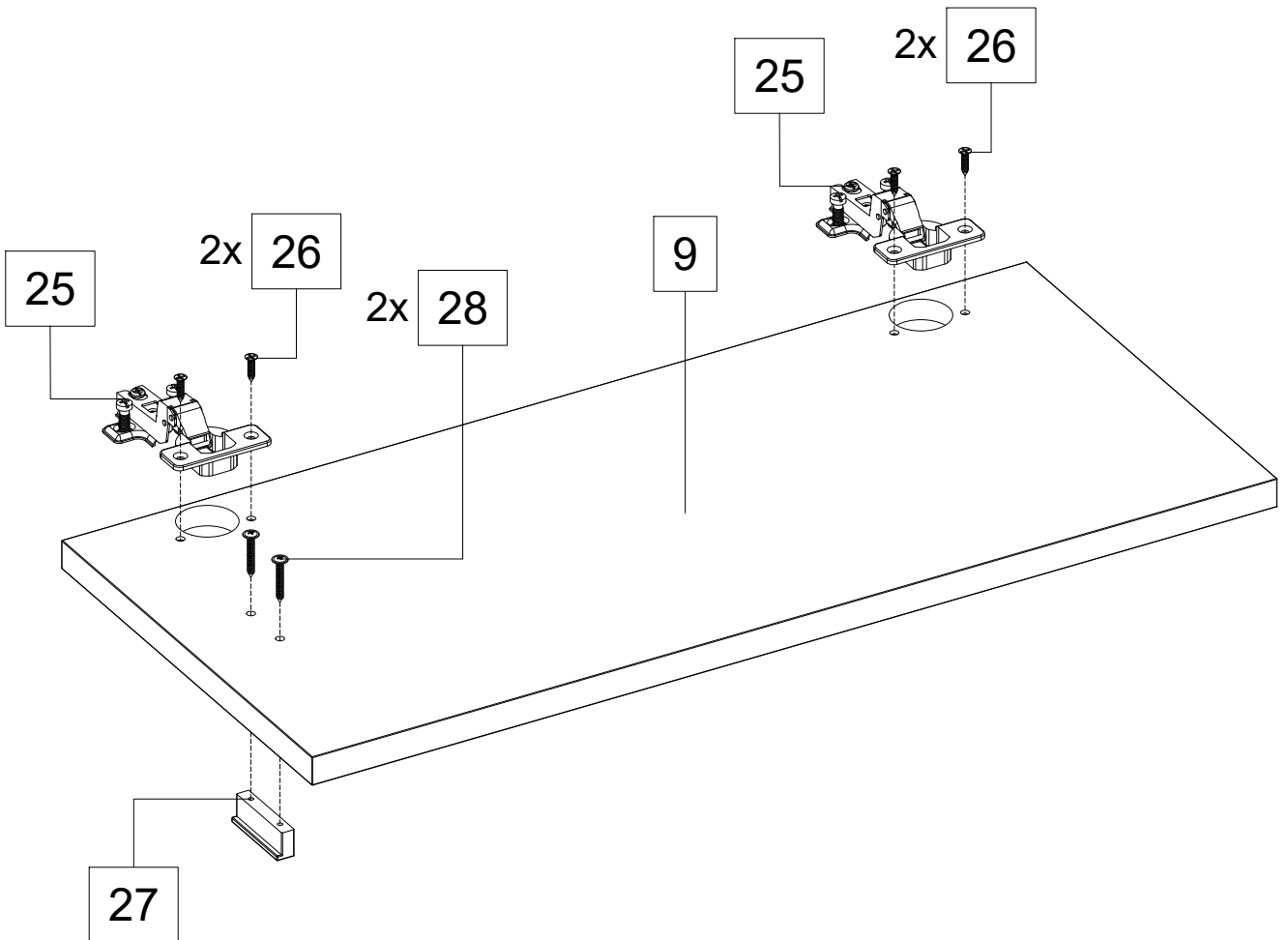
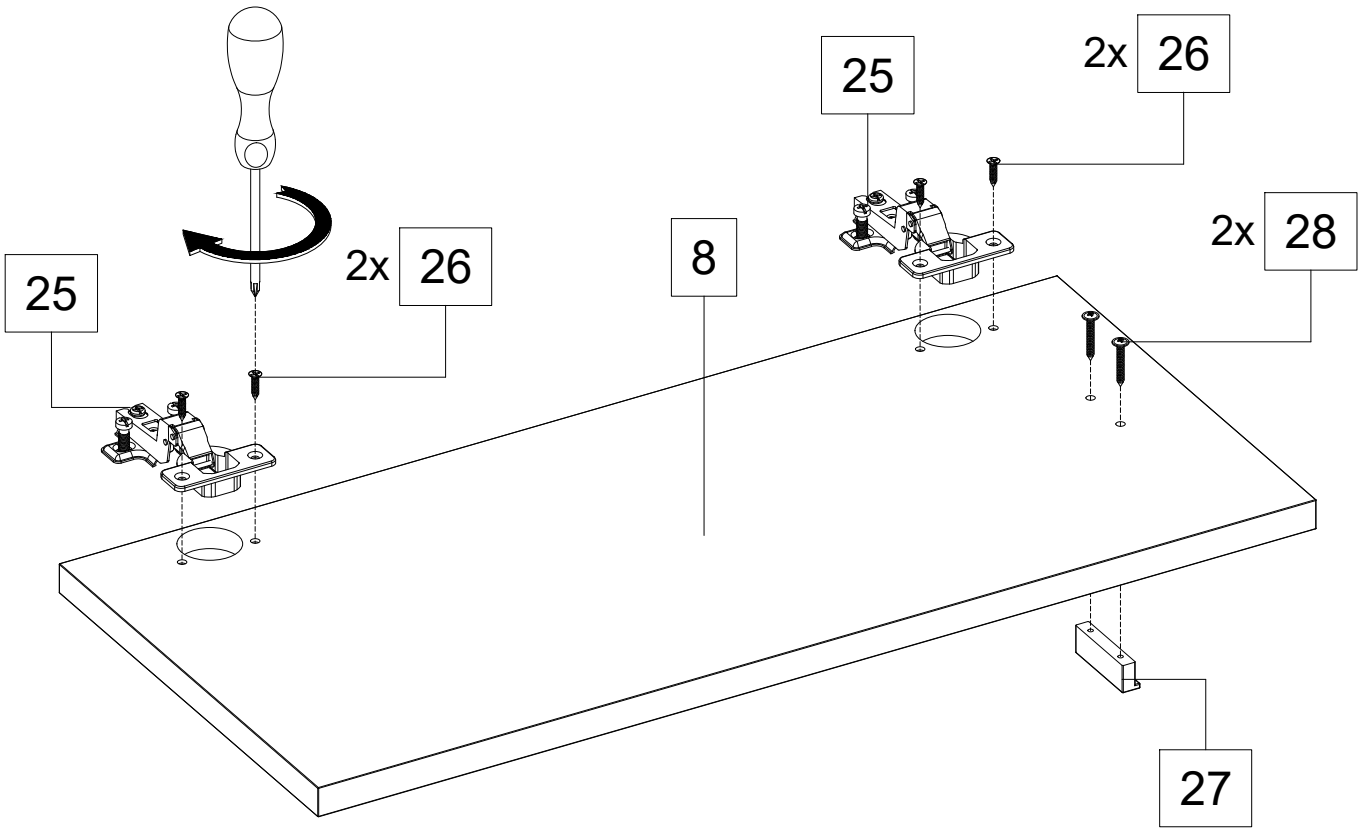
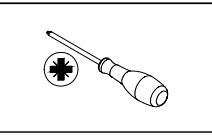
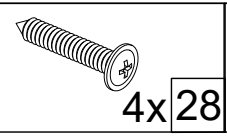
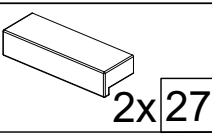
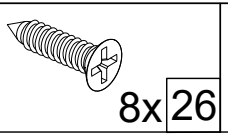
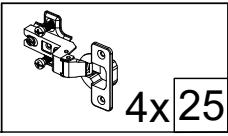

L

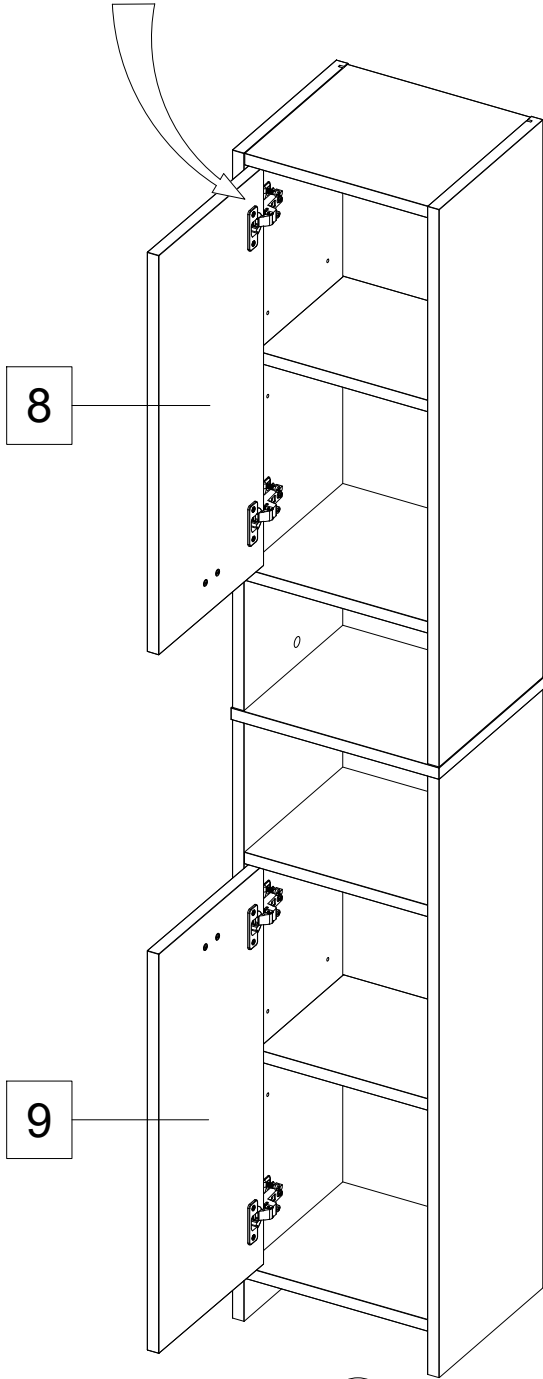
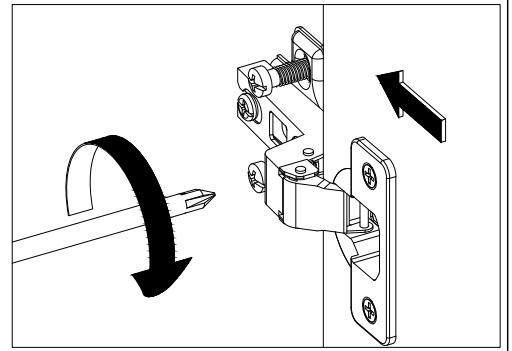
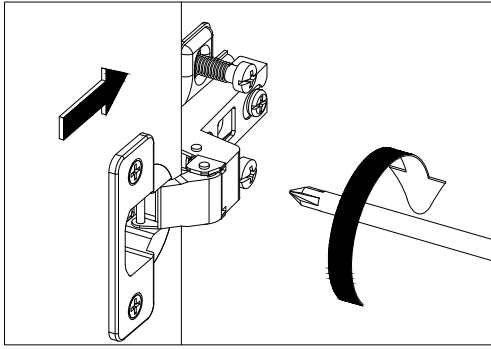
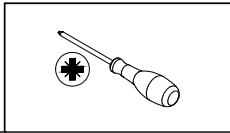

L

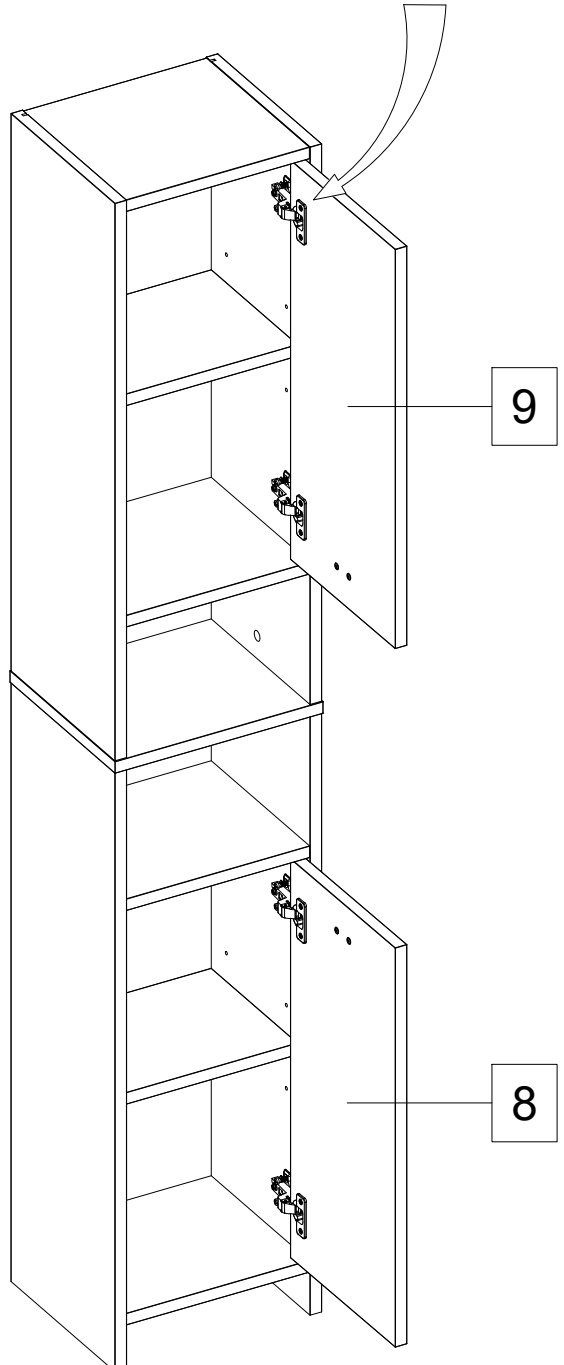

R

M

